

Vandal-proof Dome High Resolution DNR Day/Night Color Camera

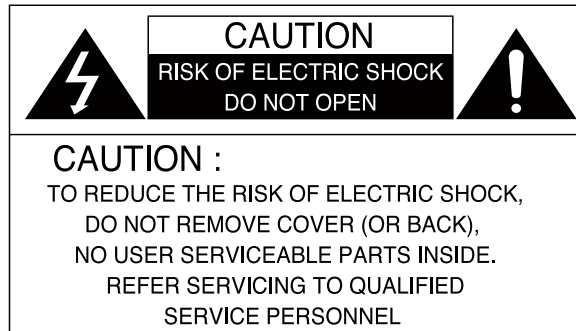

The lightning flash with an arrowhead symbol, within an equilateral triangle is intended to alert the user to the presence of uninsulated dangerous voltage within the product's enclosure that may be of sufficient magnitude to constitute a risk of electric shock to persons.



The exclamation point within an equilateral triangle is intended to alert the user to the presence of important operating and maintenance (servicing) instructions in the literature accompanying the appliance.

In USA and Canada, Use Class 2 Power Supply Only

INFORMATION - This equipment has been tested and found to comply with limits for a Class A digital device, pursuant to part 15 of the FCC Rules. These limits are designed to provide reasonable protection against harmful interference when the equipment is operated in a commercial environment. This equipment generates, uses, and can radiate radio frequency energy and, if not installed and used in accordance with the instruction manual, may cause harmful interference to radio communications. Operation of this equipment in a residential area is likely to cause harmful interference in which case the user will be required to correct the interference at his own expense.

WARNING - Changes or modifications not expressly approved by the manufacturer could void the user's authority to operate the equipment.

WARNING - To prevent electric shock and risk of fire hazards:

- ◆ Do NOT use power sources other than that specified.

Installation should be made by a qualified service person and should conform to all local codes.

IMPORTANT SAFETY INSTRUCTIONS

- 1) Read these instructions.
- 2) Keep these instructions.
- 3) Heed all warnings.
- 4) Follow all instructions.
- 5) Do not use this apparatus near water.
- 6) Clean only with dry cloth.
- 7) Do not block any ventilation openings. Install in accordance with the manufacturer's instructions.
- 8) Do not install near any heat sources such as radiators, heat registers, stoves, or other apparatus (including amplifiers) that produce heat.
- 9) Do not defeat the safety purpose of the polarized or grounding-type plug. A polarized plug has two blades with one wider than the other. A grounding type plug has two blades and a third grounding prong. The wide blade or the third prong are provided for your safety. If the provided plug does not fit into your outlet. Consult an electrician for replacement of the obsolete outlet.
- 10) Protect the power cord from being walked on or pinched particularly at plugs, convenience receptacles, and the point where they exit from the apparatus.
- 11) Only use attachments/accessories specified by the manufacturer.
- 12) Use only with the cart, stand, tripod, bracket, or table specified by the manufacturer, or sold with the apparatus. When a cart is used, use caution when moving the cart/apparatus combination to avoid injury from tip-over.



531204
Diagram 37.010 - Portable unit warning

- 13) Unplug this apparatus during lightning storms or when unused for long periods of time.
- 14) Refer all servicing to qualified service personnel. Servicing is required when the apparatus has been damaged in any way, such as power-supply cord or plug is damaged, liquid has been moisture, does not operate normally, or has been dropped.

Contents

Camera Features	5
Installing & Adjusting	6
Dimension & Specification	7
OSD Control Button	8
On Screen Display (OSD) Menu	9
Menu Set Up	10
Lens	11
Exposure	12
White Bal.	15
Day&Night	17
3DNR	18
Special	19
Adjust	24
Reset	24
Exit	24
Trouble Shooting	25

Camera Features

- **700TV Lines**

The combination of a 960H CCD image sensor and New DSP provides an excellent resolution of 700TV Lines.

- **3D-DNR**

Smart 3DNR prevents the image blurring of moving object and activates only if moving objects are appearing on the scene.

- **DIS(Digital Image Stabilizer) Function**

Stabilizes the picture and increases clarity when small amounts of motion due to wind or climate change may cause the picture to appear out of focus.

- **Smart-IR**

The "New DSP" provides a vivid image in darkness due to the control of the IR illumination sensitivity. The image is never saturated because of close objects.

- **Sens-Up**

Despite a limited & low light condition, Sens-Up - Max. x256 helps the viewer to get visible and clear images.

- **Defog**

The "Defog" function improves image clarity in poor conditions such as fog, smoke, rain or snow.

- **OSD Menu**

The On-Screen-Display Menu provides easy control and setting of all functions available in the set-up of the camera.

Installing & Components

1. Installation

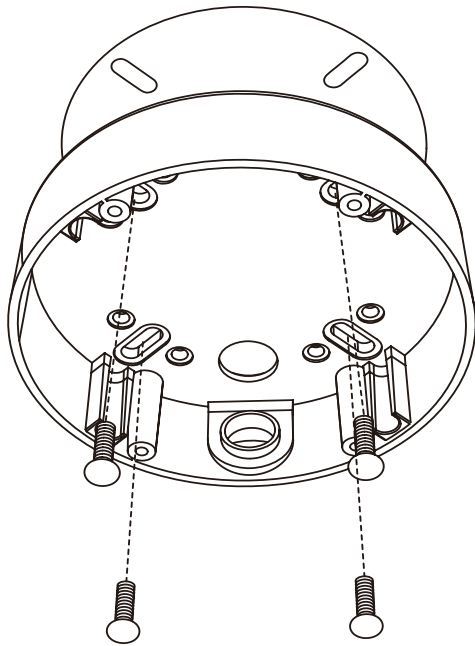

Ø5 tapping screw x 4 (supplied)

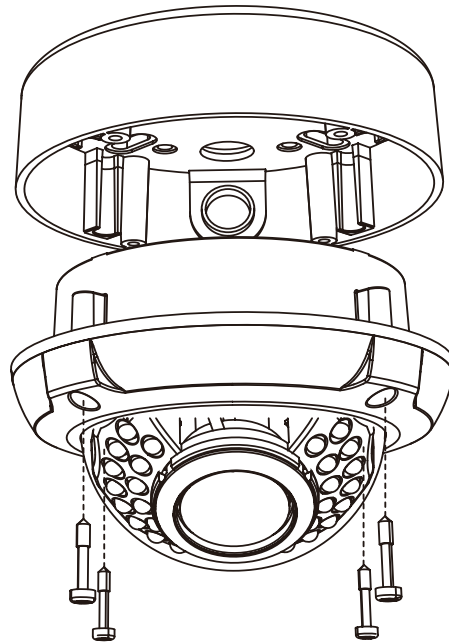

M4 Machine screw x 4 (supplied)

- Affix the mounting template to the mounting surface.
- Using the L-wrench provided, remove 4 screws and separate the dome cover.
- Drill holes in the ceiling by matching the holes in the case bed. Fix the case bed on the ceiling by using tapping screws.
- Pass the power and video cable through the access hole and connect to the camera before mounting the camera to the base.
- Position and focus the camera to a desired direction and assemble the dome cover to the mounting base with machine screws using the L wrench provided.

2. Components

- CAMERA 1piece
- Instruction Manual 1piece
- Mounting Template 1piece
- Service Monitor Cable 1pieces
- Tapping Screw 4pieces
- L-wrench 1piece

Dimension & Specification

1. Dimension & Connection

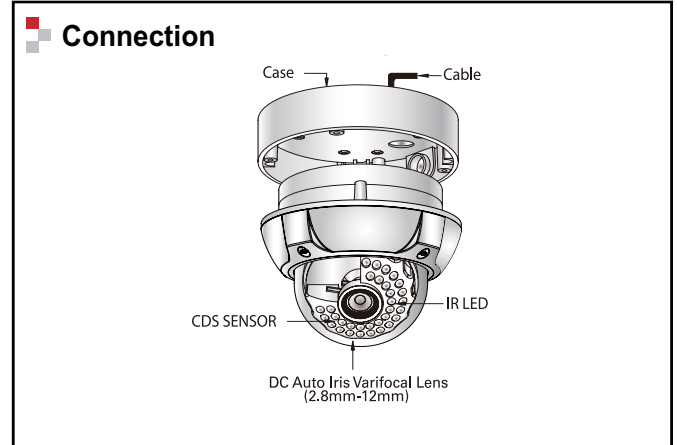
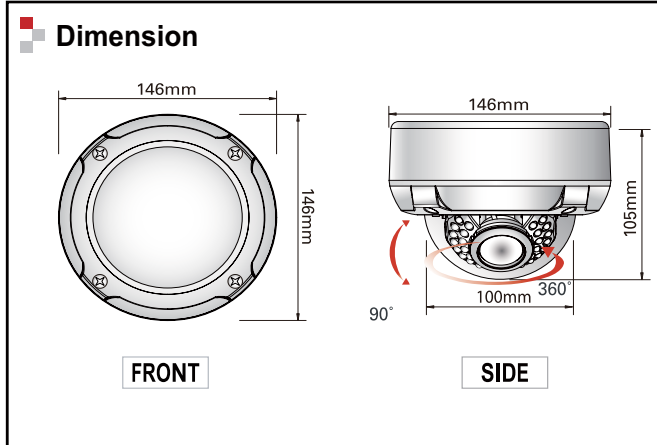



2. Specification

Sensor type	1/3" Sony 960H CCD
Effective pixels	976 (H) X 494 (V) approx. 480K pixels (NTSC) 976 (H) X 582 (V) approx. 570K pixels (PAL)
Total pixels	1020 (H) X 508 (V) approx. 520K pixels (NTSC) 1020 (H) X 596 (V) approx. 610K pixels (PAL)
Resolution	700TV Lines
Scanning system	2:1 Interlace
Min. illumination	0Lux(IR LED ON)
Video Output	1.0Vp-p Composite. 75 Ohms
S/N Ratio	52dB
AGC	Low / Middle / High
Sens-UP	OFF/AUTO (X2 ~ X256)
Backlight Compensation	OFF/BLC/HLC
D-WDR	OFF/INDOOR/OUTDOOR
Motion Detection	4 Zone
Privacy Masking	8 Zone
DIS(Digital Image Stabilizer)	OFF/ON
Day & Night	Auto(AGC)/Day/Night/Ext
White Balance	ATW/AWB/AWC->SET/Manual(1,800K ~ 11,000K)
3DNR(2D or 3D)	1 ~ 200 Level Selectable
Mirror	H-Rev / V-Rev / ROTATE/PIP
D-ZOOM	X32
SMART DZOOM	OFF/ON
DEFOG	OFF/MANUAL/AUTO
Power Supply	DC 12V/AC 24V Dual Voltage
Power Consumption	Dome : DC12V 220mA, HEATER ON : 400mA / AC24V 105mA, HEATER ON : 170mA IR LED Dome : IR LED ON : DC12V 650mA, HEATER ON : 860mA / AC24V 270mA, HEATER ON : 650mA
IR Distance	Max 30M(IR LED 33pieces)
Lens	DC Auto Iris Varifocal Lens(2.8mm-12mm)
Storage Temperature	-35° ~ +60° Deg C. RH95% MAX.
Operating Temperature	-20° ~ +60° Deg C. RH95% MAX.
Dimension(W x H x D)	146mm(W) * 105mm(H) * 146mm(D)
Weight	1500g

OSD Control Button

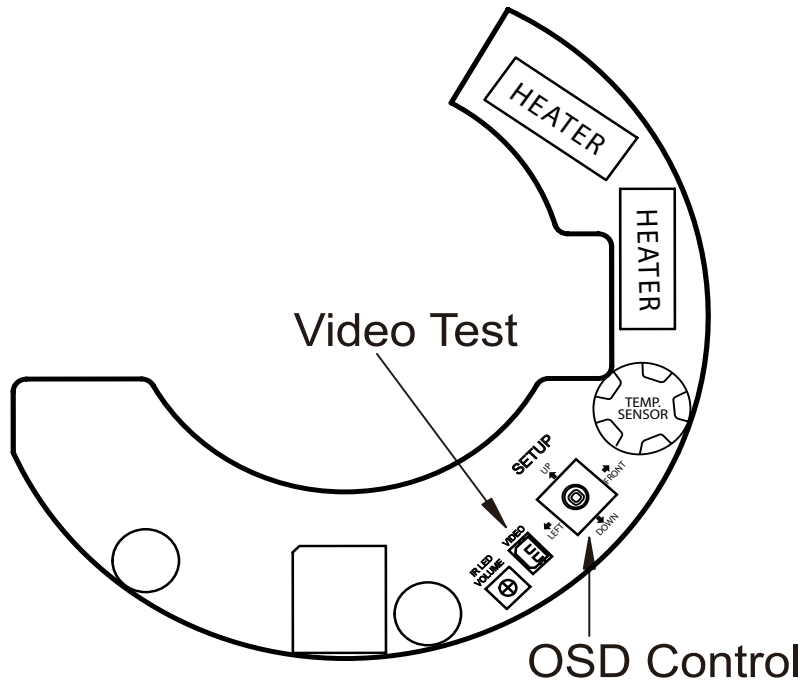
1. The OSD Button is a mini-joy stick control switch used to navigate the OSD Menu.



- ▲ Up switch : Moves the cursor upwards. Use this button to select an item or adjust the parameters.
- ▼ Down switch : Moves the cursor downwards. Use this button to select an item or adjust the parameters.
- ◀ Left switch : Moves the cursor to the left. Use this button to select or adjust the parameters of the selected item. The parameter changes each time this button is pressed.
- ▶ Right switch : Moves the cursor to the right. Use this button to select or adjust the parameters of the selected item. The parameter changes each time this button is pressed.
- ◎ Set switch (Push) : Executes selections and displays a submenu for an item with the  mark.

On Screen Display (OSD) Menu

On Screen Display (OSD) Menu

Camera functions and settings can be adjusted or changed by activating the OSD menu.

When the OSD menu is activated text will display on the monitor. The user can then move the cursor to the desired function to change the setting.

SETUP Menu

LENS	• DC	• MANUAL	
EXPOSURE	• SHUTTER • BLC	• AGC • D-WDR	• SENS-UP • RETURN
WHITE BALANCE	• ATW • MANUAL	• AWB	• AWC-->SET
DAY/NIGHT	• COLOR • EXT	• B/W	• AUTO
3DNR	• OFF	• ON	
SPECIAL	• CAM TITLE • PRIVACY • RETURN	• D-EFFECT • DEFECT	• MOTION • DEFOG
ADJUST	• SHARPNESS	• MONITOR	
RESET	• FACTORY	• RETURN	
EXIT			

Menu Set Up

Menu setting can be selected by the OSD Control switch inside the camera.

1. Press the set switch.

* The Set Up menu will be displayed on the monitor.

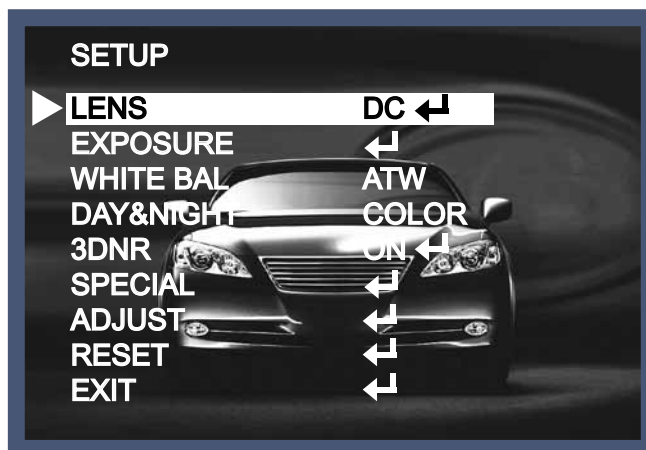

2. Move and select the required function using the Up and Down switch.

* Move the triangular indicator Up or Down to select the desired feature by moving the switch Up or Down.

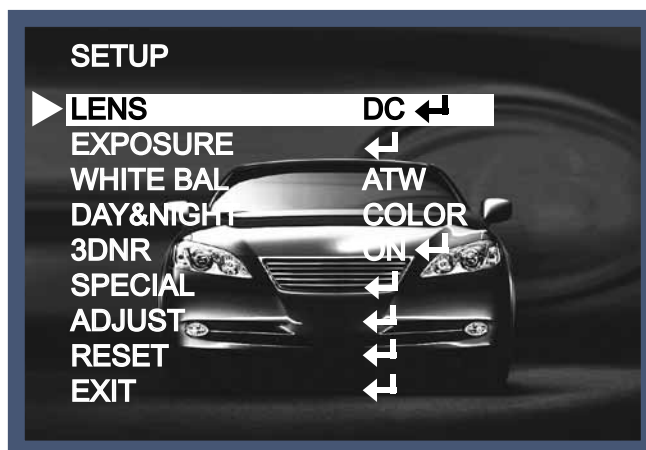

3. Change menu settings using the Left or Right switch.

* Available values or Status are displayed by moving the switch Left or Right.

Continue to press the switch until desired value / status is displayed.

4. After Changing the setting move the arrow indicator to EXIT and press SET to EXIT.

NOTE

* Move to the available submenu by moving  arrow to desired feature.

* Submenu is not available when this symbol is displayed "---".

Lens

This function is to adjust the brightness of the scene.

1. Move the triangular indicator to LENS on the Set Up menu screen.

2. Select the desired lens type by moving the switch Left or Right.

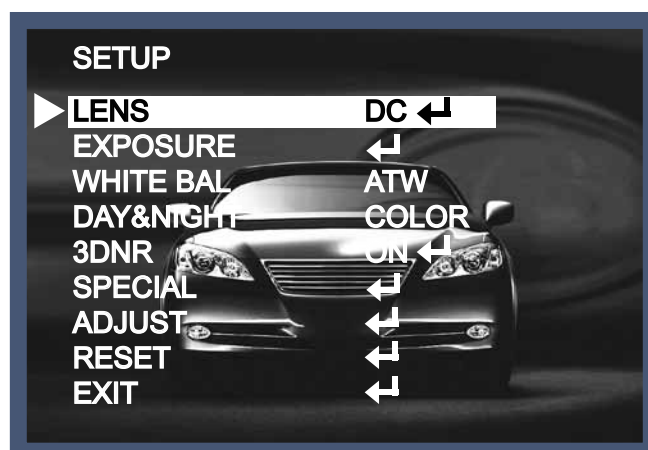

NOTE

* When DC is selected, the brightness control range is 1~100.

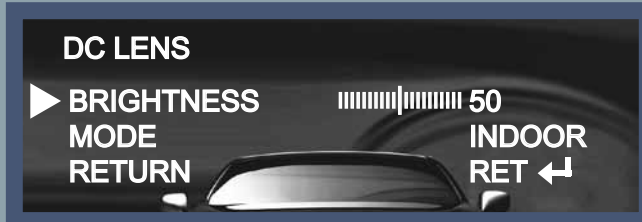

* When you select the mode setup, you can select INDOOR or OUTDOOR depending on the installation environment.

Exposure

1. In the Set Up menu, Select EXPOSURE.

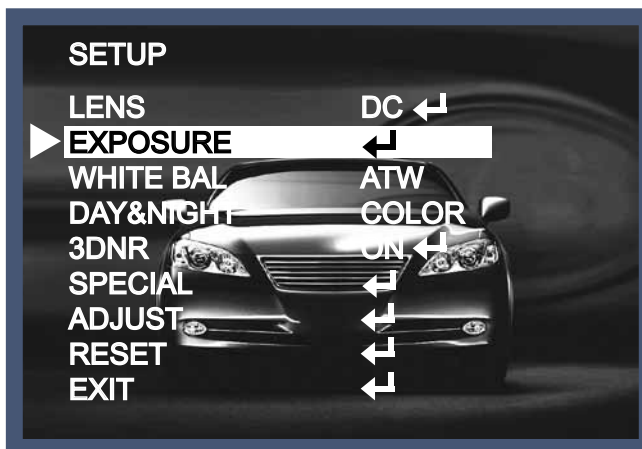

2. Select the desired shutter mode by moving the switch Left or Right.

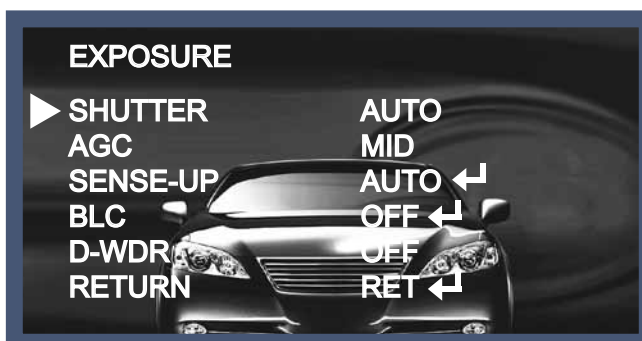

- ◆ Electronic Shutter : DC lens default is 1/60 and the manual lens default is "Auto Shutter", but the shutter speed can be adjusted from 1/60 to 1/100,000.
 - DIS (Digital Image Stabilizer) : Select the DIS mode when the image appears to have slight movement due to weather or nearby vibrations. Sense Up mode is disabled when DIS mode is active.
- ◆ AGC (Auto Gain Control) : The higher the AGC level is, the more noises is introduced into the picture.
 - Off : Deactivated.
 - Low : 28dB Gain is applied.
 - Mid : 32dB Gain is applied.
 - High : 36dB Gain is applied.

NOTE

* Sense-Up mode is disabled when Electronic shutter is selected as Manual or DIS.

- ◆ Sense-Up : A usable image can be displayed in low light conditions when set to "Auto".
 - Off : Deactivated status.
 - Auto : Sense-Up auto mode status, The degree of brightness is decided by the Sense Up setting value in the low light condition.



NOTE

* Sense Up mode is disabled when AGC mode is set to "Off".

- ◆ BLC (Back Light Compensation) : The camera with 3D-DNR provides the intelligent light level control to overcome strong backlight conditions.
 - Off : Deactivated status.
 - BLC : Select the area of interest and then set the value of the desired amount of compensation.



- HSBL (Highlight Suppression Back Light Compensation) : Small areas of very bright lights can be suppressed so that information in the darker areas of the image can be identified, i.e. car headlights.

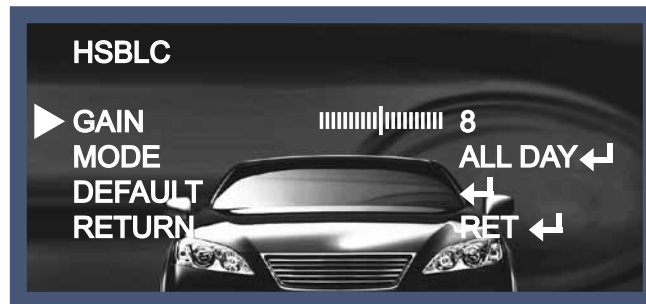

◆ D-WDR : This camera which is using 3D-DNR DSP provides intelligent light level control in a Wide Dynamic Range to overcome even strong backlight conditions.

- Off : Deactivated status.
- Indoor compensation : Used when the camera is installed indoors.
- Outdoor compensation : Used when the camera is installed outdoors.



◆ Return : Every function is set up at the EXPOSURE menu, and then return to the previous menu.

White Balance

The White Balance options may be set for best color rendition. ATW is the recommended setting.

1. Move the cursor to WHITE BAL on the SETUP menu screen.
2. Select the desired mode by moving the joystick left or right.

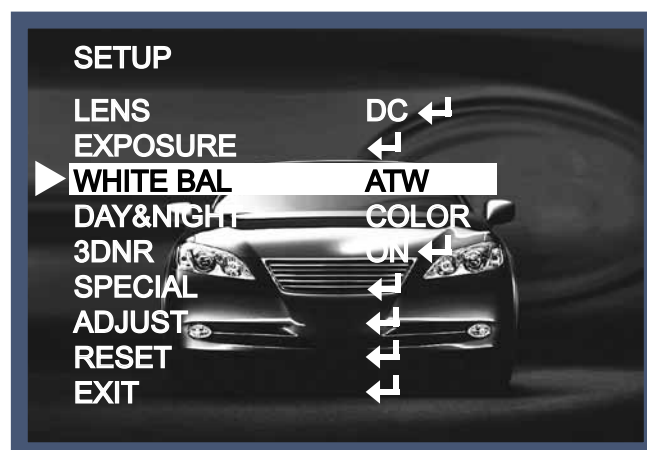

Three white balance modes are available to choose from plus manual.

- ◆ ATW : Use this mode when the color temperature is from 1,800K to 10,500K.
- ◆ AWB : This mode is for interior white balance to match ambient lighting. This mode can be used when the color temperature is from 3,000K to 7,000K.
- ◆ AWC→SET(Use for well controlled lighting conditions) : After letting camera focus on a blank white paper to current lighting environment, press the SET button. If the lighting condition changes, Re-adjustment will be needed.
- ◆ MANUAL : Manual compensation makes more detailed control possible. First, after setting the white balance using the ATW or AWB mode, change the mode to manual mode and then press Set button. While looking at the screen make the necessary adjustments to the Blue and Red values. Select return when finished.



NOTE

The White Balance may not work properly in the following conditions.

- * When there is a very high color temperature in the scene.
(for example, clear sky, Sunset)
- * It is very dark.
- * If fluorescent light is directly in the scene or if there is a drastic lighting change, The operation of White balance may become unstable.

Day&Night

1. Select Day&Night on the Set Up menu screen.
2. Select the desired mode by moving the joystick left or right.



- ◆ COLOR : Making the video output color always.
- ◆ B / W : Making the video output B/W always. (The color burst will also be disabled.)



- ◆ Auto : Automatically, selects color mode in the bright environment and the B/W mode in low light conditions. Adjust the delay time, starting brightness and end brightness according to the ambient conditions by pressing the Set button.

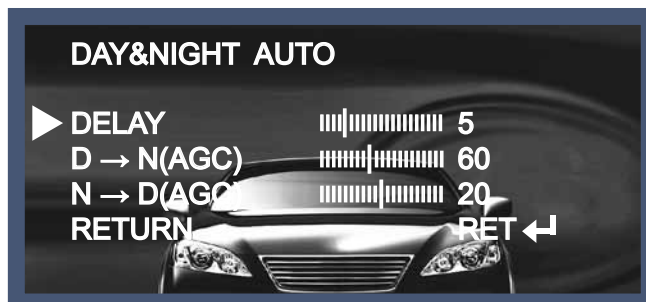

◆ EXT : This external contact to ground will change the mode from color to B/W.

3DNR

Using the 3D DNR feature of the DSP chip set will reduce the background video noise in low light conditions.

1. Move the cursor to 3DNR.
2. Select the mode by moving the joystick left or right.

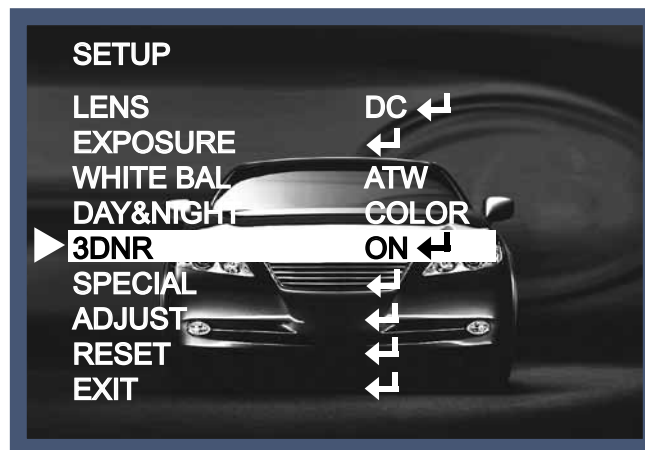

3. Off : Deactivated status.

On : Adjust the 3D DNR level for best reduction of noise in a low light scene.

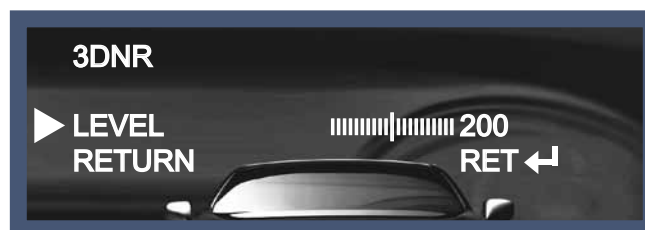

NOTE

* If 3DNR function is used, the cancellation effect of noise is excellent. The higher the compensation, the better the effect of noise cancellation is, but the ghost effect may occur.

Special

The Special section of the Setup Menu contains seven different functions.

1. When the SETUP menu is displayed, select SPECIAL.
2. Select one of the functions by moving the cursor up or down.

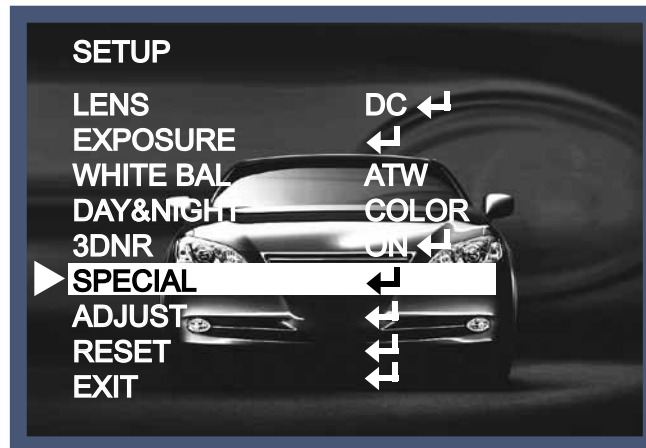

- ◆ CAM (Camera) TITLE : Up to 15 alpha numeric characters can be selected for on-screen title display. Use the cursor to select and position the characters, when finished select "END".

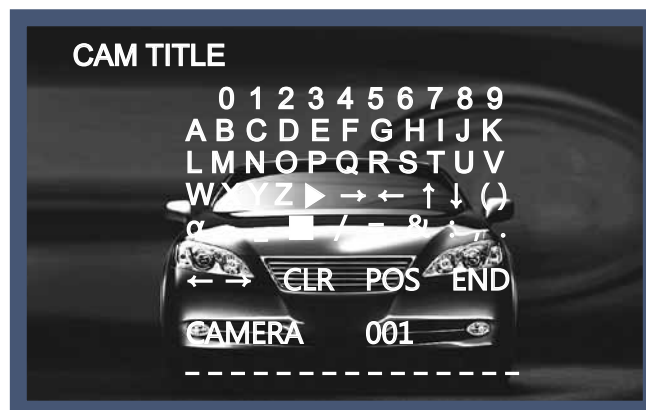

NOTE

* To erase a letter, move the cursor on the empty space in front of the number 0, and then letters will be erased by pressing the Set button one by one. Move the cursor on the "CLR", press the Set button and all the letters will be erased.

◆ D-EFFECT : The camera is always given the video image effect by this function.



→ FREEZE : The image of the monitor is paused temporarily by this function.

→ MIRROR : The image of the monitor is reversed vertically or horizontally.

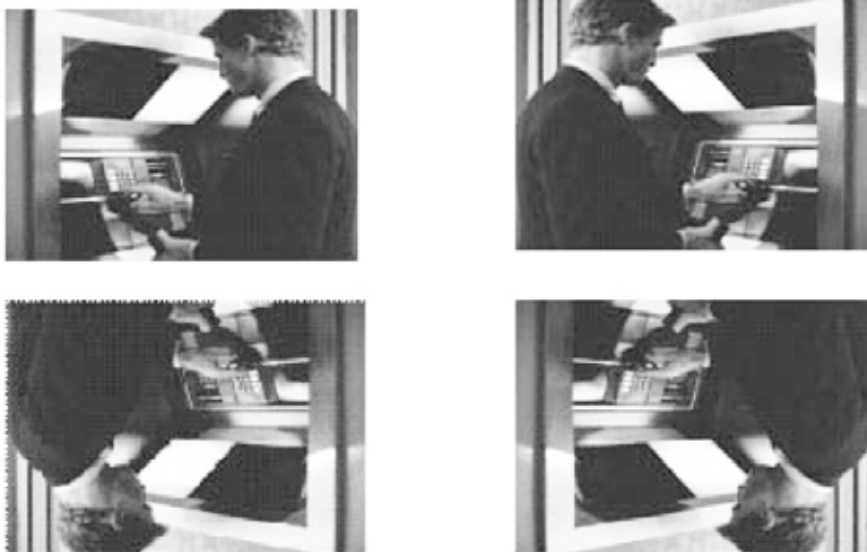

→ D-Zoom : Digital zoom with x1 ~ x32 magnification.

The higher the digital zoom magnification, the lower the resolution.



NOTE

* When using the digital zoom, SMART DZOOM and DIS cannot be used.

→ SMART DZOOM : This function is interlocked with Digital-Zoom to distinguish a specific object in more detail when there is a movement detected in a certain area. An extra sensitivity function is used to detect motions. This function works more effectively with the optical zoom

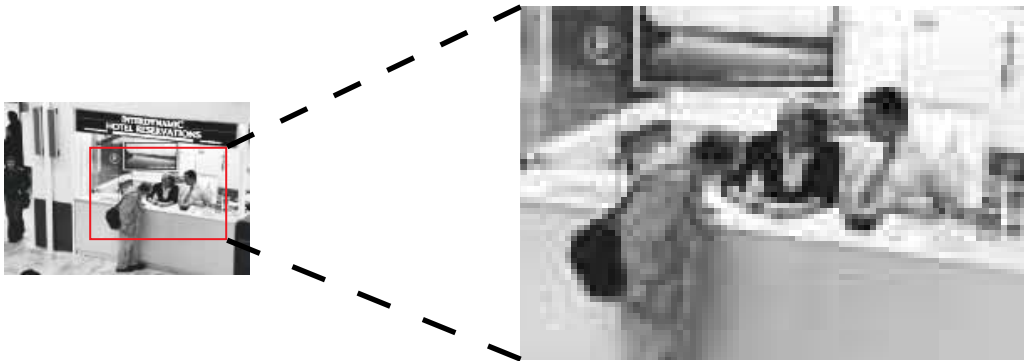

→ DIS (Digital Image Stabilizer) : DIS offers to compensate the ghost effect of an image and gives a clear image in a low light condition.



→ NEG. IMAGE

- On : Negative image.
- Off : Normal image.

→ Return : Save the digital zoom setting, then return to the SPECIAL menu.

- ◆ **MOTION** : This can detect the movement of a subject and you can see the moving image of the subject on the monitor when the camera detects it. In the state of Motion Detection On, a new submenu below appears when you press the Set button.



- Area : You can designate areas up to a maximum of 4.
 - AREA DISPLAY : After the selection of an area, the area screen should be activated On to use the motion detection function in a designated area. When this is activated, you can select the location and size of area coverage.
 - VALUE (Sensitivity) : The higher the setting value, the higher the sensitivity.
 - Motion View : If the camera detects a motion, the words "Motion Detection" appears on the monitor.
 - Return : Save the setting value of this menu, return to the SPECIAL menu.
- ◆ **PRIVACY** : This is used to hide certain areas on the monitor. You can designate up to 8 different areas. The size of a designated area can be adjusted. The color of a privacy area can be selected from 15 colors. When you select the return, the setting values in this function menu are saved.



- ◆ **SYNC** : In areas where the supply is at 60Hz(NTSC), 50Hz(PAL), phase synchronization can be set using the power synchronization function (Line-Lock)
 - INT : Internal Synchronization Type.
 - L/L : Power Synchronization Type, Line-lock(AC24V Power).
 - * Press the Function Setup switch.
 - * Select a desired phase from 0 to 359 when select 'phase'.

NOTE

- * When using AC power at 60Hz(NTSC), 50Hz(PAL), frequency, you can use the L/L type synchronization.
- * When the power is DC 12V, the SYNC menu is fixed to the 'INT' mode.

◆ DEFECT : You can eliminate white spots (defect) up to max.512 points.



- Sense Up : To eliminate defect, set the high level of Sense Up. You can set to max. 64x, but 32x is the best setting value to eliminate defect.
- DIFF : You can set the size of DEFECT from 0 to 3.
- THRESHOLD
- START : Press Set button on the "<" mark, It will start to eliminate defects "PROCESSING NOW..." will be displayed on the monitor.
- Return : Save the setting value of this menu, return to the SPECIAL menu.

◆ DEFOG : This function helps to recognize the object in a foggy or dusty weather condition.



DEFOG OFF



DEFOG ON

◆ Return : Save the setting value and get out of the current menu.

Adjust

This function is needed to control the brightness of the monitor.

1. When the Set UP menu is displayed, select ADJUST using the Up and Down button.
2. Select the desired mode by using Up or Down button.

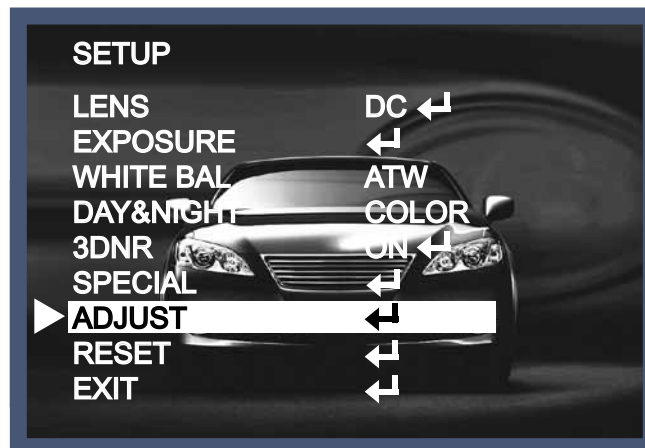

- ◆ Sharpness : The outline of an image becomes sharp and more distinct as the level of sharpness increases.
- ◆ Monitor : Change the setting value which is suitable for the monitor.
 - LCD : Select this when you use the LCD monitor.
(You can adjust the Gamma, Level, Blue& Red Gain on the submenu)
 - CRT : Select this when you use the CRT monitor.
(You can adjust the Level, Blue & Red Gain on the submenu)
 - USER : If you use a monitor with poor contrast, use the submenu and adjust the Gamma, Level, Blue & Red Gain.

Reset

The camera is set to the Factory Default value.

Exit

Press the Set button in the exit menu to save the current settings and exit the Set Up menu.

■ Trouble Shooting

PROBLEM	POSSIBLE CAUSE
Nothing appears on the screen.	☞ Check the power cable, power supply output and video connection between the camera and monitor.
The image on the screen is dim.	<ul style="list-style-type: none"> ☞ Are the camera lens or the lens glass dirty? Clean the lens / glass with a soft clean cloth. ☞ Adjust the monitor controls, as required. ☞ If the camera is facing a very strong light, change the camera position. ☞ Adjust the lens focus.
The image on the screen is dark.	<ul style="list-style-type: none"> ☞ Adjust the contrast control of the monitor. ☞ If there is an intermediate device, correctly set the 75Ω/Hi-z.
The camera is not working properly and the surface of the camera is hot.	☞ Check the camera is correctly connected to an appropriate regulated power source.
Motion Detection is not activated.	<ul style="list-style-type: none"> ☞ Has MOTION DET been set to ON in the menu? ☞ Has MD AREA been properly defined?
The color of the picture is not correct.	☞ Check the settings in WHITE BALANCE menu.
The image on the screen flickers.	☞ Make sure that the camera isn't facing direct sunlight or fluorescent lighting. If necessary, change the camera position.
The SENS-UP does not work.	<ul style="list-style-type: none"> ☞ Check that the AGC setting in the EXPOSURE menu is't set to OFF. ☞ Check the EXPOSURE menu and make sure SHUTTER is set to-----.

